

ROAD GRADE	RAMP LENGTH (12:1)	
	LOW SIDE	HIGH SIDE
≤ 1%	6'	6'
2%	6'	7'
3%	6'	8'
4%	6'	10'
≥ 5%	6'	13'

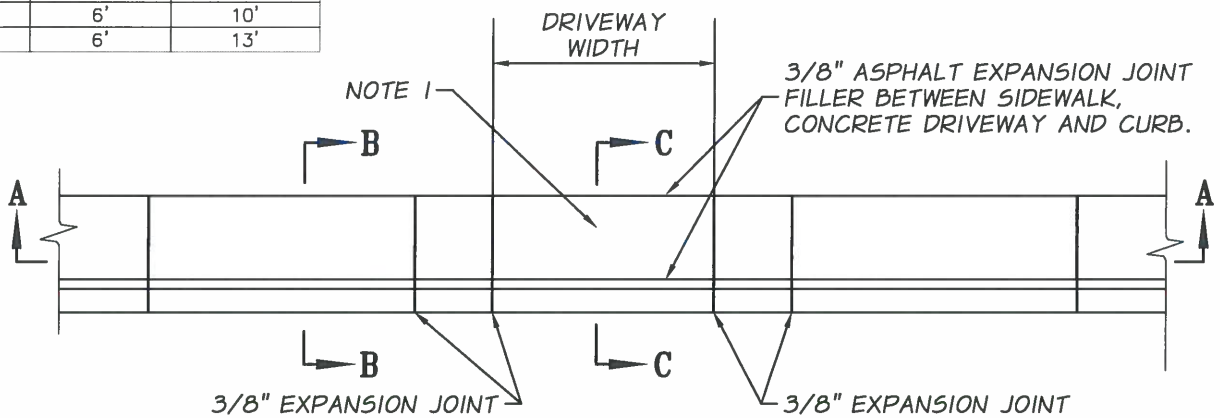

**TYPICAL DRIVEWAY ENTRANCE**  
NTS

**NEW DRIVEWAY WIDTHS:**

- 1) RESIDENTIAL DRIVEWAYS: WIDTH SEE PLANS
- 2) DEPRESSED DRIVEWAYS MUST BE SEPARATED BY AT LEAST 20.0' OF FULL HEIGHT CURB (ANY DEVIATIONS MUST BE APPROVED BY THE COUNTY ENGINEER).
- 3) FOR MOUNTABLE CURBS, SIDEWALK 0.5' MINIMUM THICKNESS.
- 4) PREMOLDED JOINT FILLER SHALL MEET THE REQUIREMENT OF SECTION 9-04.1 OF THE STANDARD SPECIFICATIONS.
- 5) FOR CEMENT CONCRETE DRIVEWAY DETAIL, SEE WSDOT STANDARD PLAN F80-10.-03. WHEN THE DRIVEWAY WIDTH EXCEEDS 20' (FT), CONSTRUCT A FULL DEPTH EXPANSION JOINT WITH 3/8" (IN) JOINT FILLER ALONG THE DRIVEWAY CENTERLINE.

**CEMENT CONCRETE DRIVEWAY ENTRANCE**



APPROVED BY: *[Signature]*  
County Engineer: \_\_\_\_\_ DATE: 5/14/15

REVISION:	DESCRIPTION:	DATE:

STANDARD PLAN  
**S-7**  
SHEET 1 OF 2

QA:Standards\STREET\S7.dwg, 1, 5/19/2015 1:08:03 PM